



Model Number

V11-W-BK2M-PUR-U-V3-GM

Connection cable, M12 to M8, PUR cable, 3-pin

Features

- UL Recognized Component
- Knurled nut suitable for tool assembly
- Immunity to vibration, with mechanical latching
- Gold plated contacts
- Flame resistant cable
- Resistant to microbes and hydrolysis
- Halogen-free
- Suitable for drag chains

Dimensions

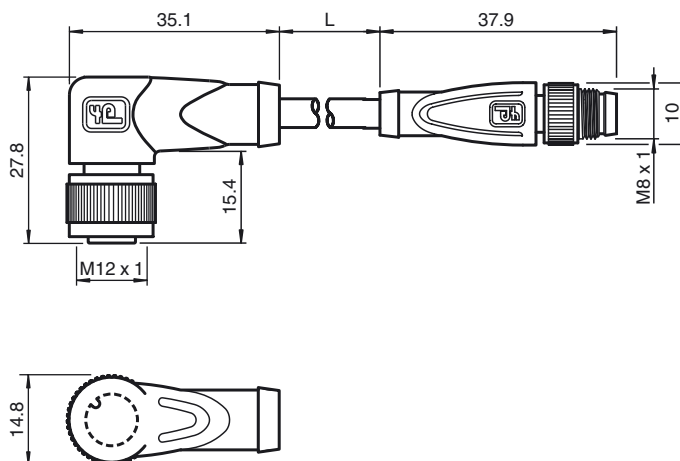

Technical data

General specifications

Number of pins	3
Connection 1	socket
Construction type 1	right angle
Threading 1	M12
Connection 2	Male connector
Construction type 2	straight
Threading 2	M8
UL File Number	E231213

Electrical specifications

Operating voltage	U _B	max. 48 V AC / 60 V DC
Operating current	I _B	max. 3 A

Ambient conditions

Ambient temperature	Body: -40 ... 90 °C (-40 ... 194 °F) cable, fixed: -40 ... 80 °C (-40 ... 176 °F) cable, flexing: -20 ... 80 °C (-4 ... 176 °F)
Pollution degree	3

Mechanical specifications

Contact elements	spring-loaded contact socket
Degree of protection	IP67 / IP68 / IP69k
Cable code	Li 9Y 11Y 3 x 0.34
Material	
Contacts	CuSn / Au
Contact surface	Au
Body	TPU, black
Cable	PUR
Slotted nut	Diecast zinc
Sleeve connector	Diecast zinc
Core insulation	PP
Cable	according to IEC/EN 60228 (DIN VDE 0295) class 6
Sheath diameter	Ø 4.3 mm
Bending radius	> 10 x cable diameter, moving > 5 x cable diameter, fixed
Color	black
Number of cores	3
Core cross-section	0.34 mm ²
Cores color	Core 1: brown Core 3: blue Core 4: black
Conductor construction	42 x 0.1 mm Ø
Length	L 2 m
Drag chain suitability	
Drag chain cycles	≥ 5000000
Motion velocity	≤ 3.3 m/s

Electrical connection

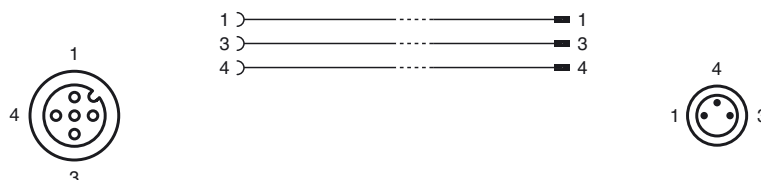

Release date: 2019-10-07 12:09 Date of issue: 2019-10-07 224654_eng.xml

Traverse distance	5 m horizontal
Acceleration	≤ 5 m/s ²
Torsion cycles	≥ 1000000
Torsional stress	± 180 °/m
Flammability	
Contact carrier	HB
Housing	V-2
Cable	FT2
Compliance with standards and directives	
Standard conformity	
Degree of protection	EN 60529
Flammability	IEC 60332-1-2
Halogen-free	IEC 60754-1
Specification	connector M12 x 1 : IEC 61076-2-101 connector M8 x 1 : IEC 61076-2-104
Approvals and certificates	
UL approval	cURus AWM 20549 AWM I/II A/B 80°C 300V FT2 (cable)
Maximum permissible operating voltage	≤ 30 V
Maximum permissible ambient temperature	≤ 80 °C (≤ 176 °F)

Release date: 2019-10-07 12:09 Date of issue: 2019-10-07 224654_eng.xml